

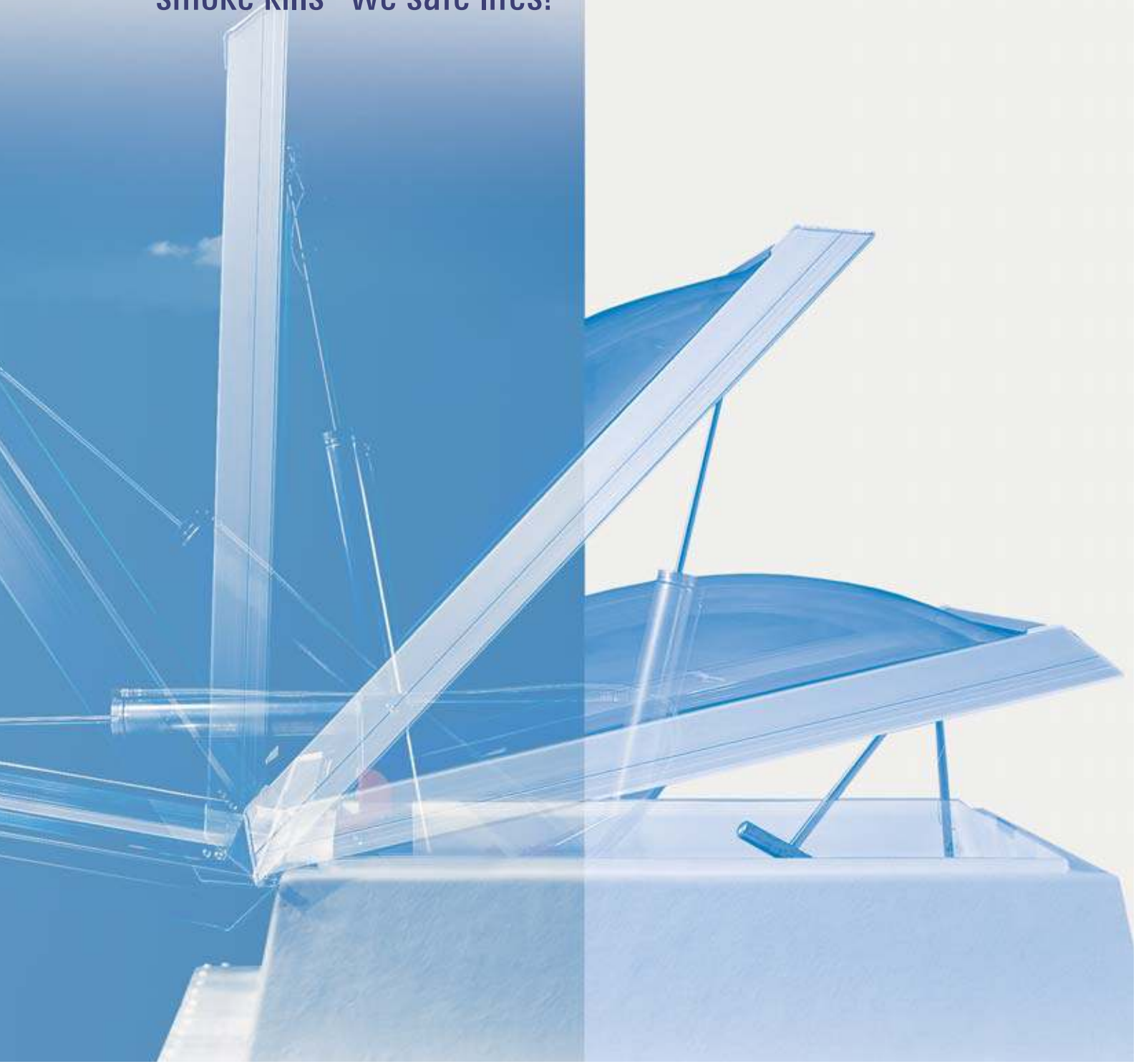

Smoke and heat ventilation systems

smoke kills - we save lives!



*Your car-maker's given you airbags.
But what have you done to make your buildings safe?*

You're obliged to provide preventive fire protection.

LAMILUX gives you the protection you're looking for.

Planners and architects find it very difficult to keep abreast of the plethora of regulations governing fire protection. And because things vary so much from one place to the next, using off-the-peg solutions may not get you very far. This is precisely where LAMILUX can help. We don't just propose using standard products; we also engineer safe, bespoke yet economic solutions complying with the relevant rules and regulations – meaning that if a fire breaks out, those liable for a building's safety can still sleep peacefully.



The most inexpensive solution for every building opening
LAMILUX smoke and heat ventilation systems

*LAMILUX
 double flaps page 8*

*LAMILUX
 smoke and heat exhaust ventilators
 Type Rauchlift page 6*

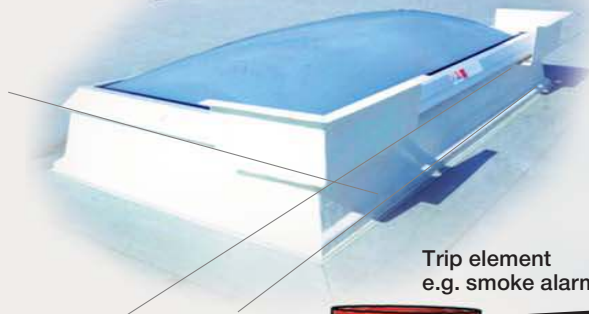

Activation of smoke extraction

Trip element
 e.g. smoke alarm



Control cabinet



Smoke and heat
 extraction
 push button



Signal to locking

Signal to position control unit

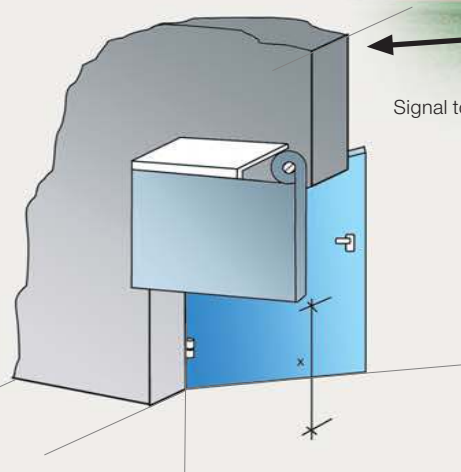

LAMILUX
 position
 control unit



defined door
 control

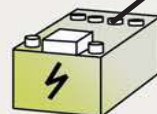

Emergency power
 72 h

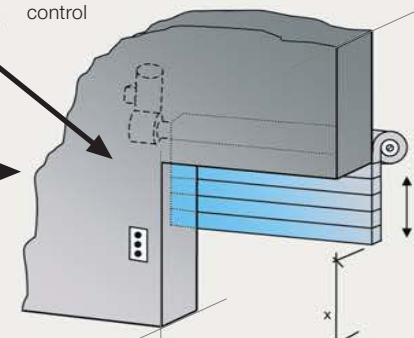

*LAMILUX
 position control systems for rolling
 shutter doors*

LAMILUX
continuous rooflights CI-System B page 10

LAMILUX
continuous rooflights
Type S
page 12

LAMILUX makes a range of modular products which ensure compliance with the applicable standards without breaking the bank. They come with optional special features, coupling smoke and heat extraction with for example blackout fixtures or permanent, rainproof ventilation.

Overall planning of smoke and heat extraction systems – to save you money

One special service offered by LAMILUX is the overall planning of smoke and heat extraction systems – to engineer the most inexpensive solution. This is made possible by LAMILUX's wide range of products including a position control system (patent applied for) with independent power supply for electric rolling shutter doors. LAMILUX devises individual smoke and heat extraction plans based on the thicknesses of the clean air layer stipulated in the relevant standards. If you wish, this can be combined with daylight calculation (DIN 5034 T 6) taking into account additional heat extraction areas (e.g. pursuant to guidelines for fire protection in industrial buildings).

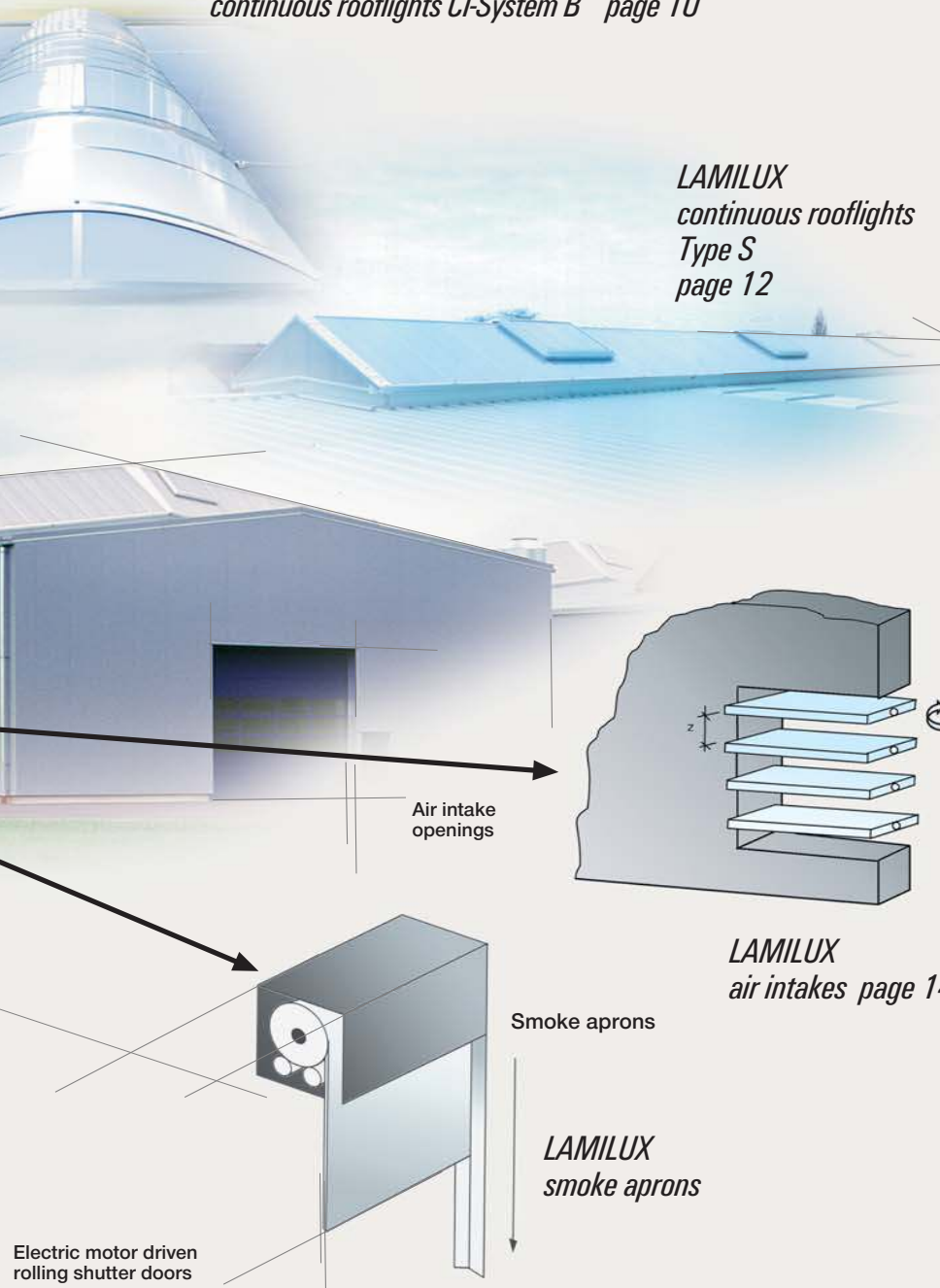

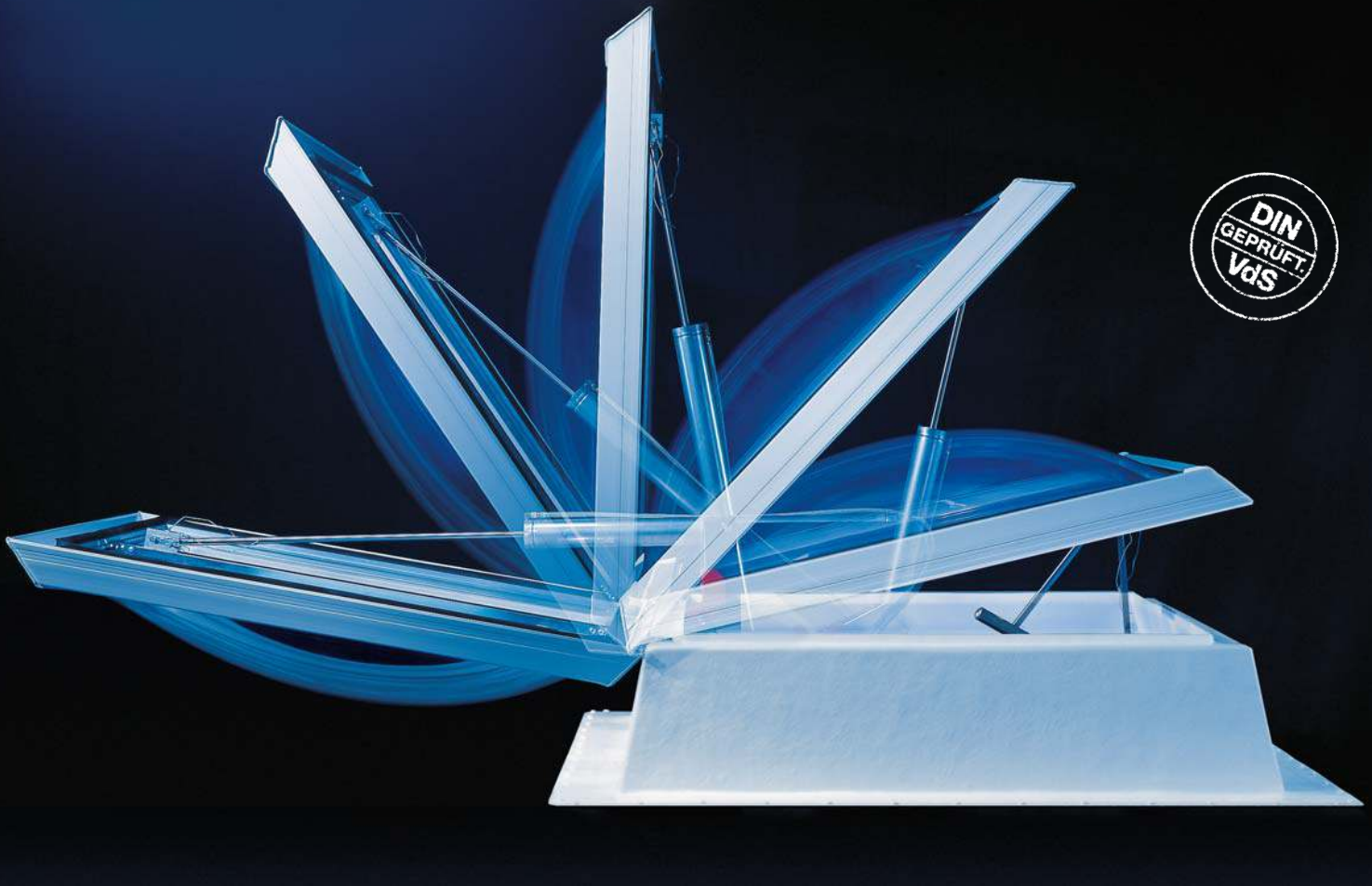

Versatile and economical

LAMILUX opening/closing smoke and heat exhaust ventilators Type Rauchlift (closing function optional)

No additional work necessary for DIN 18234 compliance

LAMILUX smoke lifts provide the high level of safety demanded by the fire department - yet are still affordable.

LAMILUX smoke and heat ventilation systems for rooflights...

- o open without impacting the roof*
- o aren't damaged by opening during testing or false alarms*
- o comply with DIN 18234 without any additional work*

LAMILUX rooflights

Function	Smoke and heat ventilation: opening, opening/closing, ventilation				
Upper section design	Glazing			Frame	Fittings
Materials	PMMA Acryl	PETG	GFRP** *	Hard PVC with special aluminium profil	Stainless steel
No chance of falling through during installation (compliant with BG guidelines)	No	Yes	Yes		
Certified hail-proof (EMPA-compliant)	No	Yes	Yes		
Building material class	B2	B1	B2*	B2/A1	A1
Building physics	$U_{g2-skin} = 2,6$ bzw. $2,7$ W/(m ² K)			$U_{g3-skin} = 1,8$ W/(m ² K)	

* Also available as hard roofing pursuant to DIN 4102, part 7

** Also available as locking palte

LAMILUX glass fibre reinforced plastic curb



Function	Ideal connection		
Curb design	Curb height: 30,40 und 50cm		
Materials	GFRP	Steel plate	Aluminium
Building material class	B2	A1	A1
DIN 18234 compliant without additional work (e.g. gravel fill)	Yes	Yes	No



Doubly safe

LAMILUX opening/closing double flaps

No additional work necessary for DIN 18234 compliance

The Lamilux double flap is an opening and closing system with an outstanding light area of up to 4,96 sq m.

The advantages of LAMILUX double flaps:

- o Large light area without spoilers*
- o High ventilation capacity*
- o Reliable winter operation since instead of conventional drainage gutters a special system*
- o Thermal CO₂ canister triggering not damaged by testing or false alarms*

LAMILUX double flap

Function	Smoke and heat ventilation: opening, opening/closing, ventilation		
Upper section design	Glazing	Frame	Fittings
Materials Size	Multi-skin polycarbonate web plates Standard up to 250cm x 250cm	Hard PVC with special aluminium profile	Stainless stell
No chance of falling through during installation (compliant with BG guidelines)	Yes		
Certified hail-proof (EMPA-compliant)	Yes		
Building material class	B2/B1	B2/A1	A1
Building physics	Ug = 1,8 bis 2,4 W/(m²K)		

LAMILUX curb

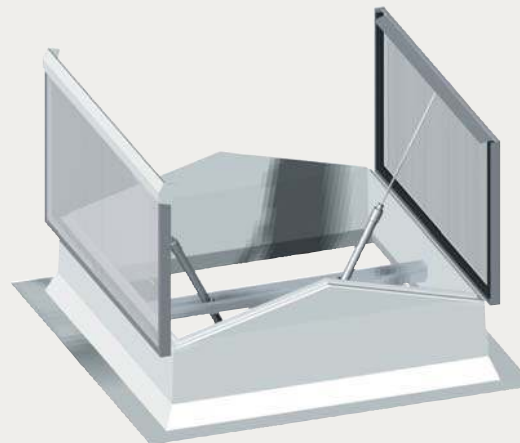

Function	Ideal connection	
Curb design	Curb height: 40 cm	
Materials	GFRP	Aluminium
Building material class	B2	A1
DIN 18234 compliant without additional work (e.g. gravel fill)	Yes	No



High - tech daylight

Smoke and heat extraction in continuous rooflights CI-System B

LAMILUX continuous rooflights CI-System B can, if required, be fitted with smoke and heat extraction equipment which fully complies with DIN 18232 and DIN EN 12101. It takes the form of integrated double flaps, which can also be controlled for use as regular and fine-weather ventilation.

New technology:

linear burn-through protection

Under DIN 18234, heavy surface protection such as gravel fill is required for large openings such as continuous rooflights. However, this is not necessary in the case of LAMILUX's new CI-System B

continuous rooflights, since the plastic/aluminium composite ensures that burning joints are automatically sealed. This prevents oxygen from penetrating and extinguishes the flames.

No flame-over, no gravel fill

The benefits of LAMILUX smoke and heat exhaust ventilation in continuous rooflight CI-System B:

- o No flame-over or gravel fill thanks to linear burn-through protection*
- o suitable as melting roof area pursuant to DIN 18230 and if required to flying sparks and radiant (hard roofing) pursuant to DIN 4102, part 7*
- o Outstanding thermal insulation*
- o Thermal CO₂ canister triggering not damaged by testing or false alarms*

LAMILUX continuous rooflights CI-System B

Function	Smoke and heat ventilation: opening, opening/closing, ventilation			
Design	Curved rooflight			
	Glazing	Frame system	Flap system	Fittings
Materials	Multi-skin polycarbonate web plates 150cm x 600cm wide	Aluminium / PVC	Aluminium / PVC	Aluminium/ stainless steel
No chance of falling through during installation (compliant with BG guidelines)	Yes			
Certified hail-proof (EMPA-compliant)	Yes			
Building material class	B1/B2	B2/A1	B2/A1	A1
Building physics	$U_g =$ 1,5 to 2,8 W/(m ² K)	$U_f =$ 1,7 to 2,7 W/(m ² K)	$U_f \leq$ 2,8 W/(m ² K)	



LAMILUX steel plate frames

Function	Ideal connection
Materials	Steel plate
Building material class	A1
DIN 18234 compliant without additional work (e.g. gravel fill)	Yes



Saddleback daylight

Smoke and heat ventilation in Type S continuous rooflights

Function	Smoke and heat ventilation opening, ventilation		
Upper section design	Saddleback continuous rooflight, 30° and 45°		
Continuous rooflight materials	Glazing	Frame system	Fittings
	Multi-skin polycarbonate web plates 30°: width 125 - 400cm 45°: width 125 - 300cm	Aluminium/PVC	Stainless steel
No chance of falling through during installation (compliant with BG guidelines)	Yes		
Certified hail-proof (EMPA-compliant)	Yes		
Building material class	B2 (B1 on request)	A1/B2	A1
Building physics	U _g = 1,7 W/(m ² K)		

If required, LAMILUX Type S continuous rooflights can be fitted with smoke and heat extraction equipment fully complying with DIN 18232 and DIN EN 12101. It takes the form of integrated double flaps, which can also be controlled for use as regular (electrical/pneumatic) and fine-weather (pneumatic) ventilation.

The benefits of LAMILUX smoke and heat extraction in Type S continuous rooflights:

- o Compliant with DIN 18232 and DIN EN 12101*
- o Suitable as melting roof area*
- o Good thermal insulation*
- o The solution for saddleback architecture*
- o Thermal CO₂ canister triggering not damaged by testing or false alarms*

LAMILUX steel plate frames

Function	Ideal connection
Materials	Steel plate
Building material class	A1
DIN 18234 compliant without additional work (e.g. gravel fill)	Yes with additional covering plate



Creative safety

Smoke and heat extraction for glass roofs

Function	Smoke and heat extraction opening, opening/closing, ventilation			
Casement design	Installation at angle between 30° and 60°			
	Glazing		Frame system	Fittings
Materials	Insulating glazing with max. opening size of 2,0 sq m	Polycarbonate glazing with max. opening size of 3,5 sq m	Aluminium with integrated screw conduit	Aluminium/ stainless steel
No chance of falling through during installation (compliant with BG guidelines)		Yes		
Certified hail-proof (EMPA-compliant)		Yes		
Building material class	A1	B2 (B1 on request)	A1	A1
Building physics	U _g = 1,1 to 3,0 W/(m ² K)	U _g = 1,8 to 2,4 W/(m ² K)		

Frame design	
Function	Ideal connection in post-centre sections and window walls
Material	Aluminium / PA
Building material class	A1/B2

The benefits of LAMILUX smoke and heat extraction for glass roofs:

- o Compliant with DIN 18232 and DIN EN 12101*
- o Almost any casement length and width available*
- o Ideal for refurbishment since it can be installed in other systems*



Controllable air intake

LAMILUX air intake units for smoke and heat ventilation

Function	Air intake for smoke and heat ventilation						
Air intake design							
	Types					Frame system	Fittings
	B-air	K-air	G-air	R-air	T-air	Aluminium/steel plate	Aluminium/stainless steel A1
Building material class*	A1/B2	A1/B2	A1/B2	A1/B2	A1	A1	
	*B1 available on request						
Frame design							
Materials	Alu- minium	Alu- minium	Alu- minium	Alu- minium	Steel plate		
Building material class	A1	A1	A1	A1	A1		
Function	Ideal connection thanks to installation flange for each window wall system (sandwich, panelled walls), concrete, masonry, timber frame or column walls, post-centre sections						

Also available with rainproof ventilation

Smoke and heat extraction also providing ventilation

Function	Smoke and heat extraction: opening, opening/closing, ventilation		
Upper section design			
	Slat type		Frame system
	Glass, aluminium or polycarbonate double web plates, all individually adapted to opening widths of 0,60 - 2,44m and heights of 0,94-2,96m		Aluminium plate
			Fittings
			Aluminium/stainless steel
Building material class	A1/B2		A1
			A1
Frame design			
Materials	Aluminium / building material class A1		
Function	Ideal connection thanks to installation flange for each window wall system (sandwich, panelled walls), concrete, masonry, timber frame or column walls, post-centre sections available		

Benefits:

- o Highly versatile - can be used in roof for smoke and heat extraction as well as air extractor, and in facade as air intake*
- o Low installation depth means blinds can be fitted in almost every type of wall*
- o Also available with rainproof ventilation*



Complete integration into building management

Control technology

If you need an expert partner who develops, engineers, installs and services bespoke control technology, look no further than LAMILUX.

How can control systems best be integrated into the building control systems?

How are the various fixtures (such as blackout systems, blinds and fire alarms) be combined with smoke extraction? Who can supply and program control systems at the high level of quality required – yet still provide top value for money? And who can coordinate all the steps involved?

These are all questions you no longer have to worry about. Simply tell us what you require of your smoke and heat extraction systems, and how you want them to be integrated into your building's I&C – and we'll do the rest!

You benefit from:

- o an integrated approach to your control systems (including engineering, installation and servicing)*
- o the combination of smoke extraction systems with various fixtures*
- o no interface problems*
- o a system design geared to individual building*
- o efficient work*
- o the right control system for your needs*
- o excellent value for money*

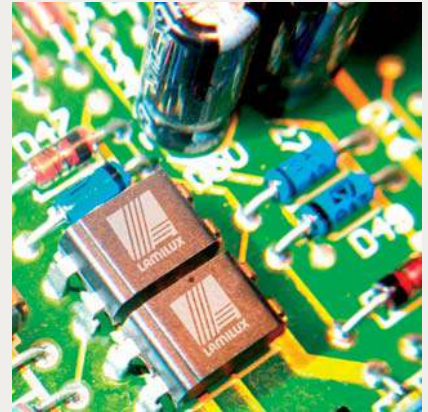



Skimp on maintenance - and you'll be in trouble

Nothing less than full working order

Operators and owners of smoke and heat extraction systems are obliged by law to take all the precautions necessary to prevent the risk of injury in the event of fire. In other words, if you neglect maintenance, you'll be breaking the law.

If you have your smoke and heat extraction systems regularly serviced, you'll minimise not only the risk of personal injury and damage to property but also your liability risk. Bear in mind that you're still liable if you cut corners on maintenance.

The advantages of having your systems serviced by LAMILUX include:

- o LAMILUX receives spare parts*
- o Servicing takes the form of comprehensive maintenance*
- o Inspection log: All test results and maintenance work are recorded in the inspection log. After taking out a maintenance contract, you'll receive this inspection log from LAMILUX free of charge. Keeping an inspection log is stipulated by DIN 18232, the VdS and in many cases local building departments*

LAMILUX smoke and heat ventilation units for stairwells

In many European countries, stairwells are covered by separate fire regulations. Stairwells usually require some form of electrically controlled smoke extraction with a separate power supply. LAMILUX supplies smoke and heat extraction systems for stairwells designed with these requirements in mind – and they're also suitable for use in other buildings, too.

LAMILUX's standard set consists of:

- 1 electric motor (500mm lift, 24V, with load interruption)
- 1 central control unit for up to 2 motors, including connection to smoke and heat extraction push buttons, ventilation buttons, and various other instruments such as smoke alarms, temperature alarms, and wind and rain sensors
- 2 smoke and heat extraction push buttons with display
- 1 ventilation button (flush-mounted installation suitable for 55m switch housing)

Individual supply and expansion possible

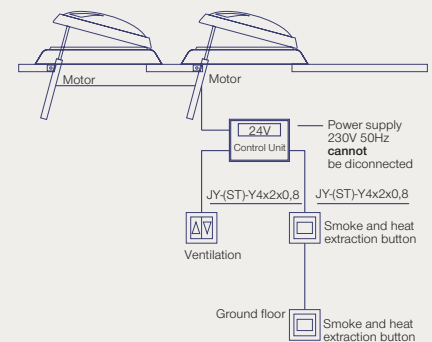

Motor wiring • Cable cross-sections

No. of motors		1	2
Max. length of wiring	3 x 1,5 sq mm	100	50
in m	3 x 2,5 sq mm	170	85
Cross-section (duplex)	5 x 2,5 sq mm	300	150

Benefits:

- o Independent power supply*
- o Electrically controlled, with ventilation option*
- o Ready-to-install kit complete with all parts required, instructions and terminal diagrams*
- o Simple for electrician to install*
- o Suitable for smoke and heat extraction in both roof and facade*

One partner instead of a string of contractors

Refurbishing smoke and heat ventilation systems

When smoke and heat extraction systems start showing their age, the right advice and quality refurbishment are often expensive and time-consuming – but not if you come to LAMILUX.

LAMILUX is the only partner you need for professional consulting, bespoke solutions, control systems and comprehensive reconditioning.

If you like, LAMILUX will be delighted to handle all the work involved in refurbishment. The first thing is to see what's in place and examine whether it complies with the latest standards and regulations in force. We also work out what the most affordable solution would be. Then we draw up a general plan, take care of the removal and disposal of unneeded fixtures, ensure the necessary safety measures are in place to protect both, people and property, and install your new systems in conjunction with our long-standing roofing partners. Our own specialists take charge of the complex control systems.



You benefit by

- o receiving a bespoke yet economical solution*
- o having refurbishment carried out as quickly as possible*
- o production continuing throughout refurbishment with a little disruption as possible*
- o saving time and hassle by have just one partner to deal with*

One partner instead of a string of contractors

Refurbishing smoke and heat ventilation systems

When smoke and heat extraction systems start showing their age, the right advice and quality refurbishment are often expensive and time-consuming – but not if you come to LAMILUX.

LAMILUX is the only partner you need for professional consulting, bespoke solutions, control systems and comprehensive reconditioning.

If you like, LAMILUX will be delighted to handle all the work involved in refurbishment. The first thing is to see what's in place and examine whether it complies with the latest standards and regulations in force. We also work out what the most affordable solution would be. Then we draw up a general plan, take care of the removal and disposal of unneeded fixtures, ensure the necessary safety measures are in place to protect both, people and property, and install your new systems in conjunction with our long-standing roofing partners. Our own specialists take charge of the complex control systems.



You benefit by

- o receiving a bespoke yet economical solution*
- o having refurbishment carried out as quickly as possible*
- o production continuing throughout refurbishment with a little disruption as possible*
- o saving time and hassle by have just one partner to deal with*



Skimp on maintenance - and you'll be in trouble

Nothing less than full working order

Operators and owners of smoke and heat extraction systems are obliged by law to take all the precautions necessary to prevent the risk of injury in the event of fire. In other words, if you neglect maintenance, you'll be breaking the law.

If you have your smoke and heat extraction systems regularly serviced, you'll minimise not only the risk of personal injury and damage to property but also your liability risk. Bear in mind that you're still liable if you cut corners on maintenance.

The advantages of having your systems serviced by LAMILUX include:

o LAMILUX receives spare parts

o Servicing takes the form of comprehensive maintenance

o Inspection log: All test results and maintenance work are recorded in the inspection log. After taking out a maintenance contract, you'll receive this inspection log from LAMILUX free of charge. Keeping an inspection log is stipulated by DIN 18232, the VdS and in many cases local building departments



Skimp on maintenance - and you'll be in trouble

Nothing less than full working order

Operators and owners of smoke and heat extraction systems are obliged by law to take all the precautions necessary to prevent the risk of injury in the event of fire. In other words, if you neglect maintenance, you'll be breaking the law.

If you have your smoke and heat extraction systems regularly serviced, you'll minimise not only the risk of personal injury and damage to property but also your liability risk. Bear in mind that you're still liable if you cut corners on maintenance.

Under VdS (the German Association of Property Insurance Companies) guidelines, servicing may only be carried out by firms who have access to critical spare parts made by the company which built the smoke and heat extraction system in the first place.

The advantages of having your systems serviced by LAMILUX include:

- o LAMILUX receives spare parts from all main manufacturers*
- o Servicing takes the form of comprehensive maintenance*
- o Inspection log: All test results and maintenance work are recorded in the inspection log. After taking out a maintenance contract, you'll receive this inspection log from LAMILUX free of charge. Keeping an inspection log is stipulated by DIN 18232, the VdS and many cases local departments*

Wer regelt was

Welche Normen und Vorschriften gelten für Sie

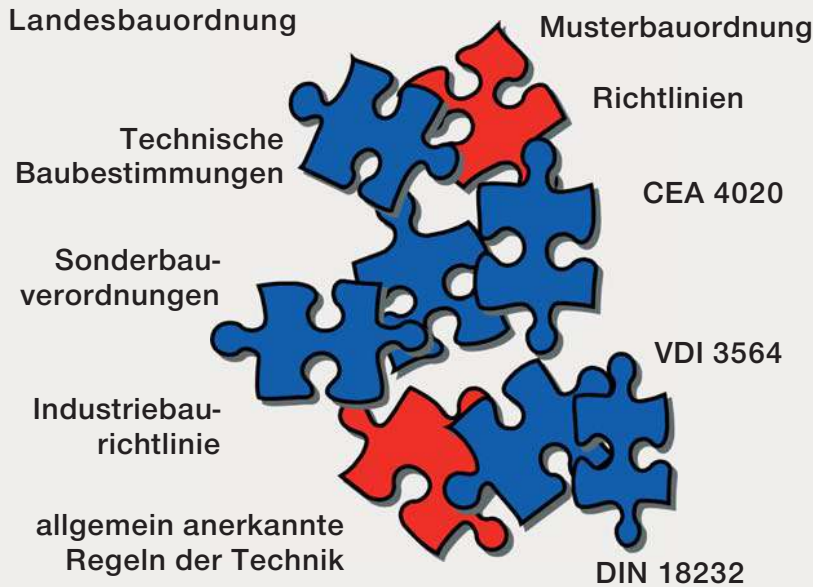

LAMILUX Projektierungsservice bietet:

- objektspezifische Projektierung nach DIN 18232-2 oder CEA 4020
- RWA Variantenbetrachtung für eine maßgeschneiderte Lösung unter Beachtung der Randbedingungen wie Gebäudeeigenheiten, behördliche Auflagen, Brandschutzgutachten etc.
- Zuluftprojektierung als integraler Bestandteil eines schlüssigen Gesamtkonzeptes mit Einbeziehung der bauseitigen Gebäudeabschlüsse und ihrer Ansteuerung im RWA-Fall.

Lamilux-Projektierungsservice:

Der sicherste und kostenintelligenteste Weg zur Lösung des Vorschriftenpuzzles.

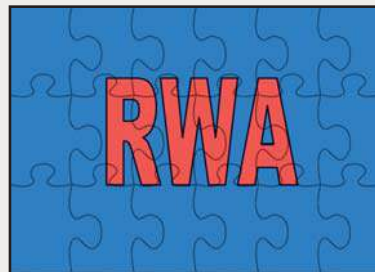

Schulungen wie von Ihnen gewünscht unsere Schulungsabteilung bietet Kunden, Planern, Feuerwehr und Behörden Informationsveranstaltungen nicht nur zur neuen DIN 18232-2 in Verbindung mit anderen Regelwerken, oder über geeignete Maßnahmen gegen Brandüberschlag bei Dachdurchdringung nach DIN 18234, sondern auch über individuell vorgegebene Themen.



Safety variations

Control systems for smoke and heat exhaust ventilators (DIN 18232 and EN 12101 compliant)

smoke and heat exhaust ventilators type Rauchlift

CO₂ opening

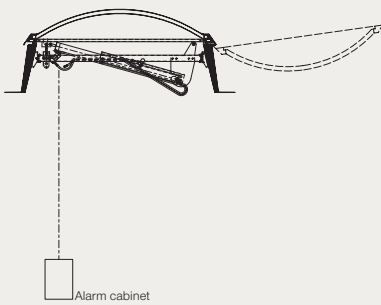

CO₂ opening + electrical ventilation

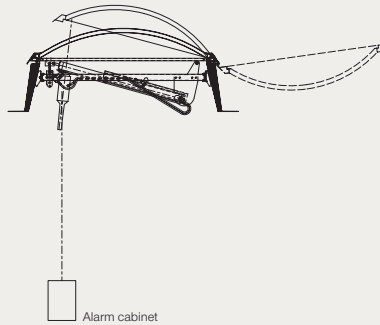

CO₂ opening + pneumatic ventilation

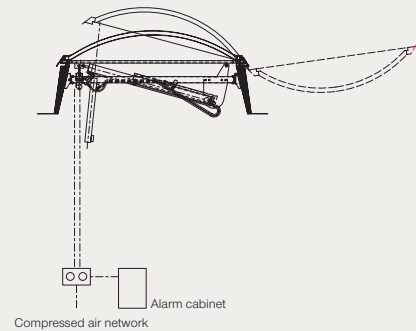

- o No ventilation
- o 1-pipe system required
- o Closed from the roof

- o 1-pipe system required
- o Closed from the roof

- o Compressed air supply required
- o 2-pipe system required
- o Closed from the roof during maintenance

CI Sytem B smoke and heat exhaust ventilators

CO₂ opening

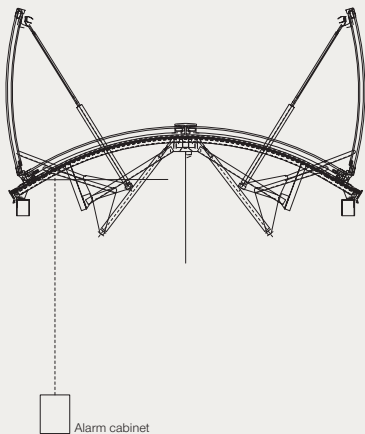

CO₂ opening + pneumatic ventilation

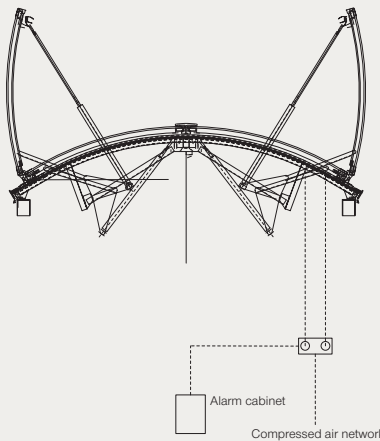

CO₂ opening + electrical ventilation

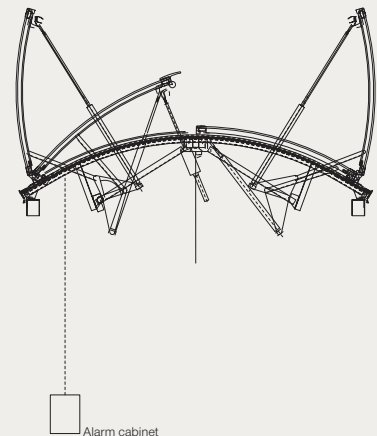

- o No ventilation
- o 1-pipe system required
- o Closed from the roof

- o Compressed air supply required
- o 2-pipe system required
- o Can be opened and closed from below
- o Ventilation flaps open up to 90°

- o 1-pipe system required
- o Closed from the roof

KWS 60 smoke extraction

CO₂ opening

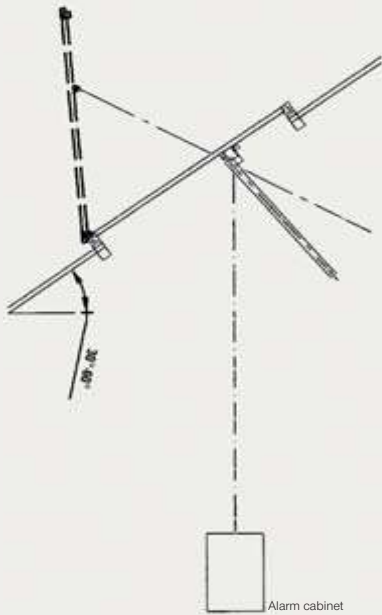

- o No ventilation
- o 1-pipe system required
- o Closed from the roof

CO₂ opening + pneumatic ventilation

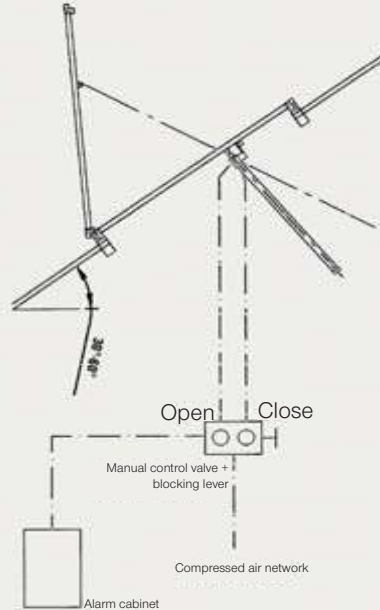

- o Compressed air supply required
- o 2-pipe system required
- o Can be opened from below
- o Ventilation flaps open up to about 60°

CO₂ opening + electrical ventilation

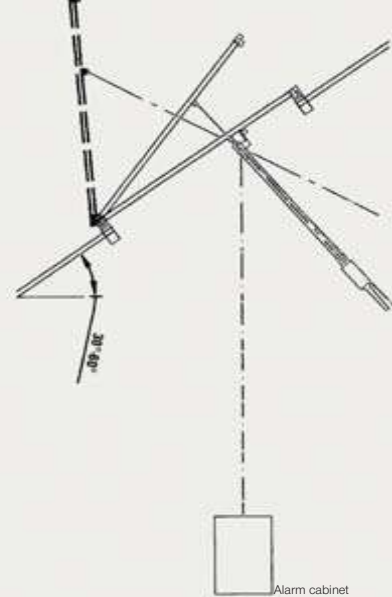

- o 1-pipe system required
- o Closed from the roof during maintenance
- o Lifting height: 300mm
- o No compressed air required



1. Alarm cabinet for hand operation
2. Thermal tripping for automatic opening
3. Pneumatic ventilation cylinder
4. Opened by electric motor

LAMILUX smoke and heat exhaust ventilatores

Type Rauchlift with sloping curb		Type Rauchlift with upright curb and spoiler		Double-flap smoke and heat extraction	
Size	Aerodynamic free area (sq m)	Size	Aerodynamic free area (sq m)	Size	Aerodynamic free area (sq m)
100/100	0,60	100/100	0,75	100/100	0,750
100/150	0,90	100/150	1,12	100/150	1,125
100/200	1,30	100/200	1,50	100/200	1,500
100/240	1,56	100/240	1,80	100/240	1,800
100/250	1,62	100/250	1,87	100/250	1,875
120/120	0,93	120/120	1,08	120/120	1,080
120/150	1,17	120/150	1,35	120/150	1,350
120/180	1,40	120/180	1,62	120/180	1,620
120/240	1,87	120/240	2,16	120/240	2,160
125/125	1,01	125/125	1,17	125/125	1,170
125/250	2,03	125/250	2,34	125/250	2,340
130/250	2,11	130/250	2,43	150/150	1,687
140/250	2,28	140/250	2,62	150/180	2,025
150/150	1,46	150/150	1,68	150/200	2,250
150/180	1,75	150/180	2,02	150/210	2,362
150/200	1,95	150/200	2,25	150/240	2,700
150/210	2,05	150/210	2,36	150/250	2,812
150/240	2,34	150/240	2,70	180/180	2,430
150/250	2,44	150/250	2,81	180/240	3,240
180/180	2,10	180/180	2,43	180/250	3,375
180/240	2,81	180/240	3,24	200/200	3,000
180/250	2,93	180/250	3,37	200/250	3,750
200/200	2,60	200/200	3,00	250/250	4,687
		100/300	2,25		
		120/300	2,70		
		150/300	3,37		

CI-System B continuous rooflight	
Size	Aerodynamic free area (sq m)
150/200	2,01
200/200	2,72
250/200	3,44
300/200	4,15
150/100	1,11
200/100	1,51
250/100	1,79
300/100	2,16

Type S continuous rooflight	
Size	Aerodynamic free area (sq m)
150/I	1,093
250/I	1,762
150/II	1,244
250/II	2,005
150/III	1,697
250/III	2,963

KWS 60 smoke extraction
 Max. geometrical opening:
 2,0 sq m (glass)
 3,5 sq m (polycarbonate)

Aerodynamic free area =
 $0,65 \times \text{clear width} \times \text{clear height}$

DH 172 automatic rooflight opener

for LAMILUX domelights (DIN 18232 certified)



Description

- o Integrated 24V DC opening system for connection to rooflights*
- o Maximum opening angle 172°*
- o Fast opening (less than 60 seconds)*
- o Usable for ventilation, smoke and heat removal*
- o Low power consumption*

This rooflight opening system has been specially designed for LAMILUX domelights. It opens domelights up to 150cm × 150cm in size to an angle of 172° in under 60 seconds. The powerful ZA300 rack drive is based on the VdS-approved ZA153/500. The system has been tested with a domelight for a lifetime of more than 11,000 opening-and-closing operations at normal load.

It can be used in conjunction with VdS-certified control and tripping systems to produce complete smoke and heat extraction systems*. It can also be used for ventilation with its lifting height controlled by the central control system or a ventilation push button.

A thermo-maximum or thermo-differential detector needs to be included for compliance with DIN 18232.

LAMILUX CI-SYSTEMS

**ROOFLIGHTS F80
SMOKE AND HEAT EXHAUST VENTILATORS
TYPE RAUHLIFT**



**LIGHT ARCHITECTURE F
LIGHT ARCHITECTURE M**

CONTINUOUS ROOFLIGHTS B



CONTINUOUS ROOFLIGHTS S

WINDOW WALLS



REFURBISHMENT

LIGHT ARCHITECTURE KWS60



SMOKE APRONS

SUPPLY AIR DEVICES



**SMOKE AND HEAT CONTROL
TECHNOLOGY**

The technical specifications contained in this brochure were correct at the time of going to press and are subject to change. Our technical details are based on calculations, information received from suppliers, and the findings of independent testing in accordance with the applicable standards. Heat transfer coefficients for LAMILUX plastic glazing were calculated using the method of finite elements with reference values taken from EN 673 for insulating glass. Taking into account practical considerations and the specific characteristics of plastic, the temperature difference between external surfaces was defined as 15K. The functional values refer solely to test specimens with the dimensions for which testing was planned. No further guarantee can be given for technical values, especially if the situation regarding installation changes or measurements are revised on site.



HEINRICH STRUNZ GMBH

Zehstraße 2 · Postfach 1540 · 95111 Rehau/Germany · Tel.: +49 92 83/5 95-0 · Fax: +49 92 83/5 95-29 0

E-Mail: information@lamilux.de · www.lamilux.com

